

SCI series screw impeller pump



APPLICATION

SCI series submersible/dry screw pump are designed for economical and reliable pumping of sewage water from commercial, communal and industrial sources. Mainly can be used in municipal engineering, sewage treatment environmental protection engineering, industrial engineering, hotel, hospital, civil air defense, mining and other industries, can be used for delivery of solid particles and long fiber wastewater, wastewater, storm water and city living water, and even can be used for in vivo delivery.

Used in conjunction with the automatic coupling system the below ground level wet installation is a particularly economical solution which also does not damage the environment

The pump are also suitable for quick portable applications

MODEL DESCRIPTION

SCI - XX - XX D/Z/G - 2/4/6/8

| | | | |__Motor pole

| | | |____Special speed

| | |____Motor power (X10)

| |____Motor stator outer diameter

|____Screw centrifugal pump

PRUDUCT FEATURE



Centrifugal submersible sewage pump, when running on the H-Q curve, power is not overloaded, applicable to water level changes, unstable conditions occasions or site emergency drainage; also applies to lift or flow high condition; also for sewage medium in municipal engineering and cotton, slaughter plant containing more fiber impurities; The front end of impeller can stir the wastewater, it applicable to the sewage contain medium solid particles . After the effluent was discharged by the sewage pump ,there is no precipitate left in the pool , without regularly clean up the sewage pool.

TECHNICAL DECRPTION

Motor: the unique insulation design ensures the motor can still run normally if little water is in the chamber of motor. The optimal design of

motor guarantees that the pump is able to start running when the hydraulic parts is submerged by some mud and sands.

Motor submerged: continuous operation S1

Insulation grade: H, Medium temperature: Up to 40°C

Hydraulic parts: processed with advanced CFD flow field diagnose technology, it has many merits like high efficiency, no block and anti-corrosion etc. the impeller is adopted semi-open single or double vane with cutter design, they have large flow channel to ensure that large solid can be passed.

Sealing design: we take many improvement measures for pump sealing, adopt two double mechanical seal design, which enable the product to be safer and more reliable

Protection measures: leakage protection in oil chamber, motor overload protection

Material: pump casing, volute is GG25, impeller is GGG60 (option SS304, SS316), mechanical seal is SiC/SiW (with anti-winding function) , cable is heavy rubber set soft cable, duty voltage 450/750V, PVC outer sheathed copper conductor

PRODUCT STRUCTURE SECTION

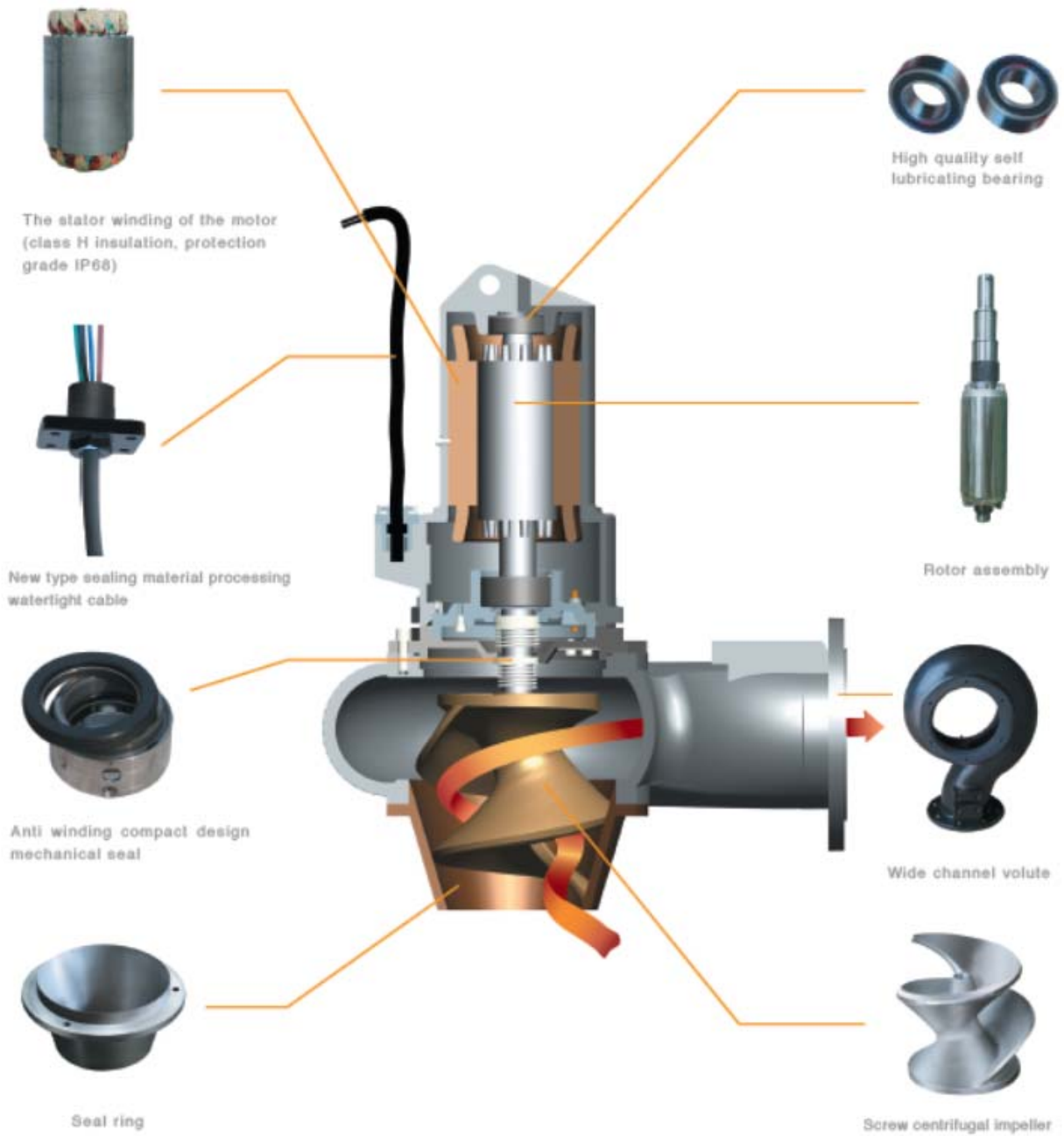

PERFORMANCE CURVE

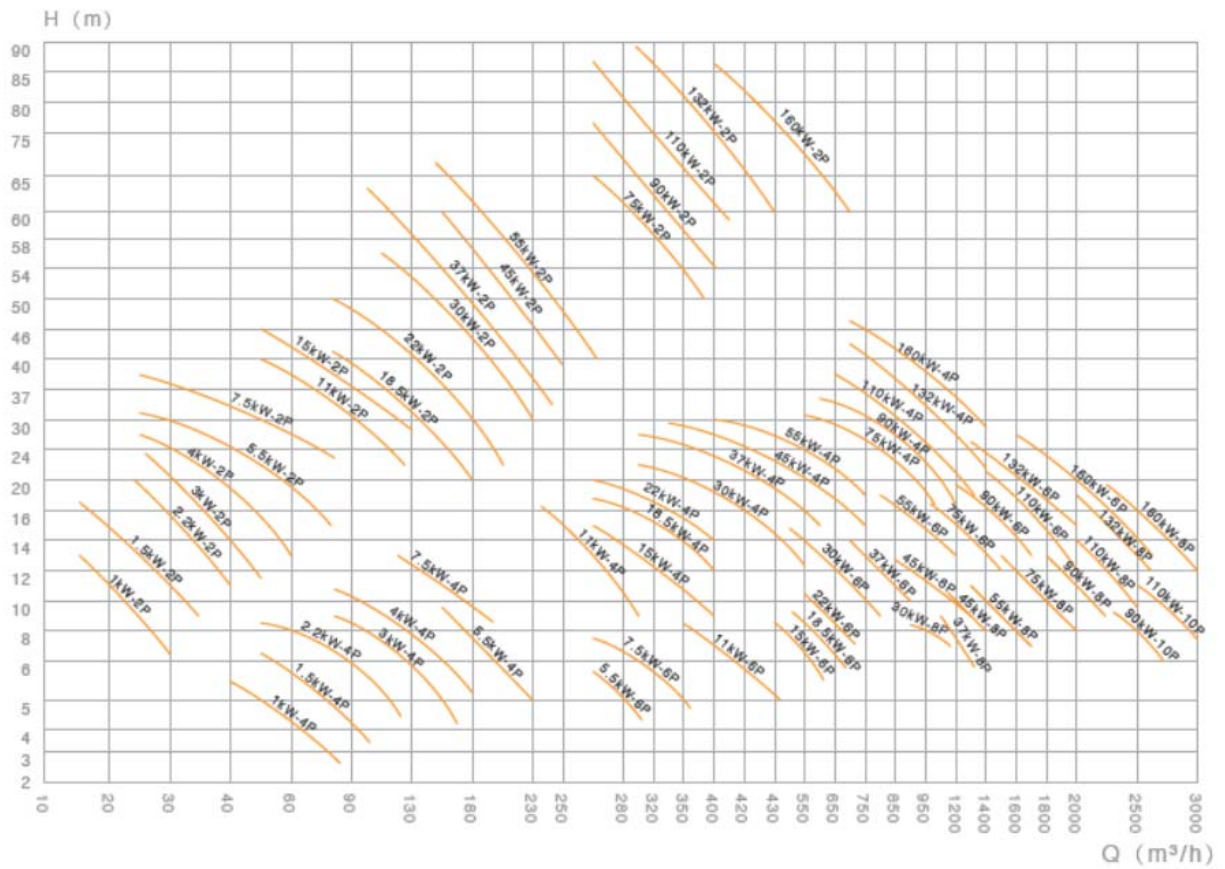

TECHNICAL DAT

Item . No.	Model	Capacity (m3/h)	Head (m)	Power (Kw)	Discharge (mm)	Speed (r/min)	Max solids Passed (mm)	Connection flange	Weight (kg)
1	SCI10610D2	8--25	14--5.5	1	56	2900	33	65	28
2	SCI10610Z4	30-45	3.5--2.5	1	100	1490	54	100	40
3	SCI10615D2	10--30	15--6	1.5	56	2900	36	65	28
4	SCI10615Z4	35-60	5--3	1.5	100	1490	59	100	45
5	SCI13522D2	14--40	19--8	2.2	66	2900	39	80	55
6	SCI13522Z4	45-100	8--3.5	2.2	120	1490	63	150	50
7	SCI13530D2	15--50	20--9	3	66	2900	41	80	56
8	SCI13530Z4	60-125	8.5--4	3	120	1490	67	150	55
9	SCI15040D2	20-60	25--9.5	4	71	2900	43.5	80	78
10	SCI15040Z4	65-150	9--4.5	4	129	1490	71	150	80
11	SCI17055D2	25-75	28--10	5.5	80	2900	46	80	100
12	SCI17055Z4	80-170	9.5--5	5.5	150	1490	76	150	160

Item . No.	Model	Capacity (m3/h)	Head (m)	Power (Kw)	Discharge (mm)	Speed (r/min)	Max solids Passed (mm)	Connection flange	Weight (kg)
13	SCI17055H4	120-250	7.5--3.5	5.5	170	1490	115	200	150
14	SCI17075D2	35-90	30--13	7.5	80	2900	49	80	105
15	SCI17075Z4	90-200	12.5-6	7.5	150	1490	81	150	170
16	SCI17075H4	140-300	8.5--4	7.5	170	1490	123	200	160
17	SCI20011D2	40--110	35--15.5	11	92	2900	53	100	165
18	SCI20011Z4	130-260	15--7	11	175	1490	87	200	280
19	SCI20011H4	190-400	10--4.5	11	187	1490	132	200	270
20	SCI20015D2	50-140	40--17.5	15	92	2900	57	100	170
21	SCI20015Z4	150-300	17--8	15	175	1490	93	200	300
22	SCI20015H4	240-500	11.5-5	15	200	1490	140	200	290
23	SCI23018D2	55-160	45--19.5	18.5	100	2900	59	100	200
24	SCI23018Z4	170-350	19--9	18.5	185	1490	97	200	360
25	SCI23018H4	280-600	13-5.5	18.5	210	1490	147	200	350
26	SCI23022D2	60-170	50--21.5	22	100	2900	61	100	220
27	SCI23022Z4	190-400	21--9.5	22	185	1490	100	200	380
28	SCI23022H4	300-650	14--6	22	217	1490	152	200	370
29	SCI25030D2	70-200	55--24	30	111	2900	65	150	240
30	SCI25030Z4	230-500	23--11	30	205	1490	107	200	550
31	SCI25030H4	370-800	15.5--6	30	240	1490	162	250	540
32	SCI25037D2	80-230	60--25	37	111	2900	68	150	250
33	SCI25037Z4	250-550	26--12	37	205	1490	111	200	580
34	SCI25037H4	400-900	17--7	37	240	1490	169	250	570
35	SCI28045D2	100-280	65--28	45	118	2900	71	200	300
36	SCI28045Z4	300-600	27---13	45	215	1490	116	250	640
37	SCI28045H4	450-1000	18.5--8	45	250	1490	176	250	630

INSTALLATION SYSTEM

Wet installation

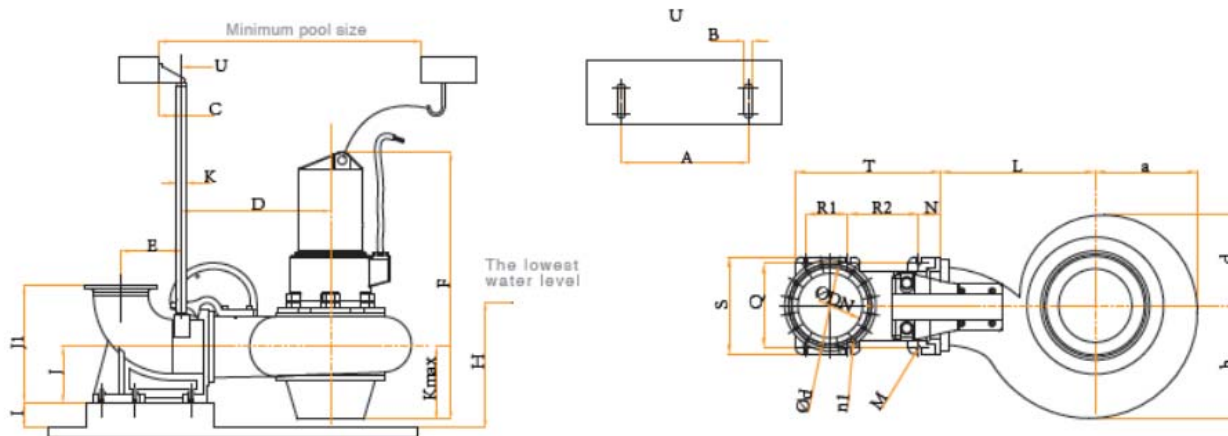

Type	DN	A	B	C	D	E	F	I	J
65AC	Rc5/2"	90	18	85	281	130	428	0	157
80AC	Rc3"	90	18	100	329	174	520	50	205
100AC	Rc4"	115	18	100	451.5	210	800	80	220
150AC	Rc6"	115	18	100	533	244	765	150	250
200AC	Rc8"	180	20	180	700	300	3100	250	305
250AC	Rc10"	180	20	180	742	348	3540	400	340
300AC	Rc12"	220	20	180	899	400	3920	450	402
400AC	Rc16"	300	20	180	1170	475	3920	450	438

Type	J1	Kmax	H	K	a	b	d	L	T
65AC	255	73	338	32	105	111	105	211	400
80AC	343	76	365	32	118	124	118	233	450
100AC	402	110	450	60	174.5	184	174	321.5	650
150AC	474	215	600	60	225	305	270	403	850
200AC	571	330	740	60	370	370	370	553	900
250AC	698	430	970	60	360	430	310	639	1200
300AC	780	480	1100	76	500	705	720	999	1300
400AC	920	570	1100	76	640	705	855	1034	1400

Type	S	Q	R1	R2	N	Ød	n1	M	g1xg2(min)
65AC	380	160	200	0	31	Φ145	4-Φ20	4-Φ22	900x550
80AC	400	140	240	0	40	Φ160	8-Φ20	4-Φ22	1200X900
100AC	600	200	305	0	40	Φ180	8-Φ22	4-Φ22	1200x900
150AC	650	270	350	0	46	Φ240	8-Φ22	4-Φ22	1400x1000
200AC	690	300	420	0	93	Φ295	8-Φ22	4-Φ26	1500x1200
250AC	800	340	460	0	108	Φ350	12-Φ22	4-Φ26	1700x1300
300AC	880	400	180	430	100	Φ400	12-Φ22	6-Φ28	2200x1700
400AC	900	520	260	440	135	Φ515	16-Φ26	6-Φ28	2250x1700

Portable installation

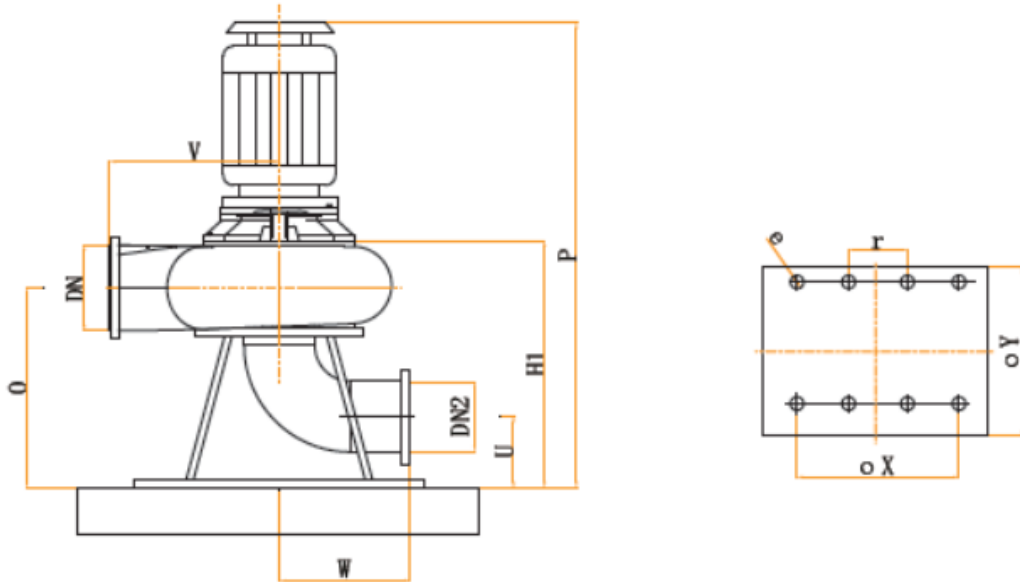

Type	DN	P	U	V	W	□X
65AC	Rc5/2"	915	115	280	280	380
80AC	Rc3"	1100	165	380	280	380
100AC	Rc4"	1100	200	430	300	400
150AC	Rc6"	2425	245	450	330	500
200AC	Rc8"	2850	295	450	360	680
250AC	Rc10"	3220	295	523	360	680
300AC	Rc12"	3680	450	870	650	1200
400AC	Rc16"	3680	450	870	650	1200

Type	r	□Y	e	O*	H1*	DN2
65AC	0	500	4-Φ28	600	680	150
80AC	0	500	4-Φ28	650	720	150
100AC	0	500	4-Φ28	701	820	200
150AC	0	600	4-Φ28	741	847	250
200AC	0	800	4-Φ32	839	1021	300
250AC	0	800	4-Φ32	853	1037	300
300AC	400	800	4-Φ34	1100	1350	500
400AC	400	1000	4-Φ34	1100	1350	500